

# E-Series Hopper Loader

## 100% Corrosion-Free, Stainless Steel Construction!



Molders Choice E-Series hopper loaders quickly convey free-flowing virgin granules and regrind to your injection molding machine.

The integral, single-phase suction motor creates a flow of air that carries the plastic granules into the hopper through the material line for a pre-selected time. The granules are then discharged directly into the processing machine hopper. The cycle is repeated until both the machine hopper and hopper loader are full.

### Easy Access / Quick Cleanup

The hinged vacuum head ensures quick cleanup time and easy maintenance.

### Reliable Performance

All units have microprocessor control and digital display of loading time, loading function, and mode selection. Fault diagnosis is a standard. All models are built to the highest standards from quality stainless steel – providing consistent, reliable performance.

### Design Features:

- Stainless steel construction
- Fabric vacuum filter with stainless mesh backing
- Low noise vacuum head
- Mechanical flap valve
- Electrical control and loader head set up for future centralized system
- Electrical circuit built to comply with CE safety requirements
- 115V single phase

### Options:

- Material line cleaning valve and suction box
- Two-component proportioning valve
- Self-cleaning filter
- 220V single phase

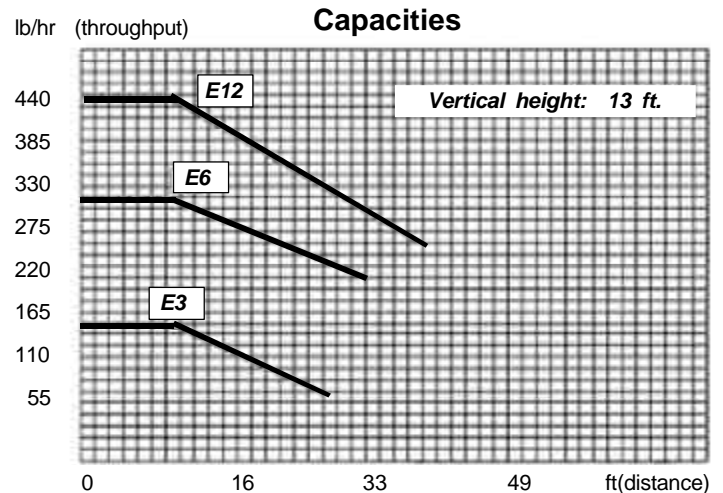

© 2004 MOLDERS CHOICE, Inc.



24 Hour Service - 7 Days a week

**1-800-809-4623**

WebSite: [www.molderschoice.com](http://www.molderschoice.com) • Email: [molders@molderschoice.com](mailto:molders@molderschoice.com)

# E-Series Hopper Loader

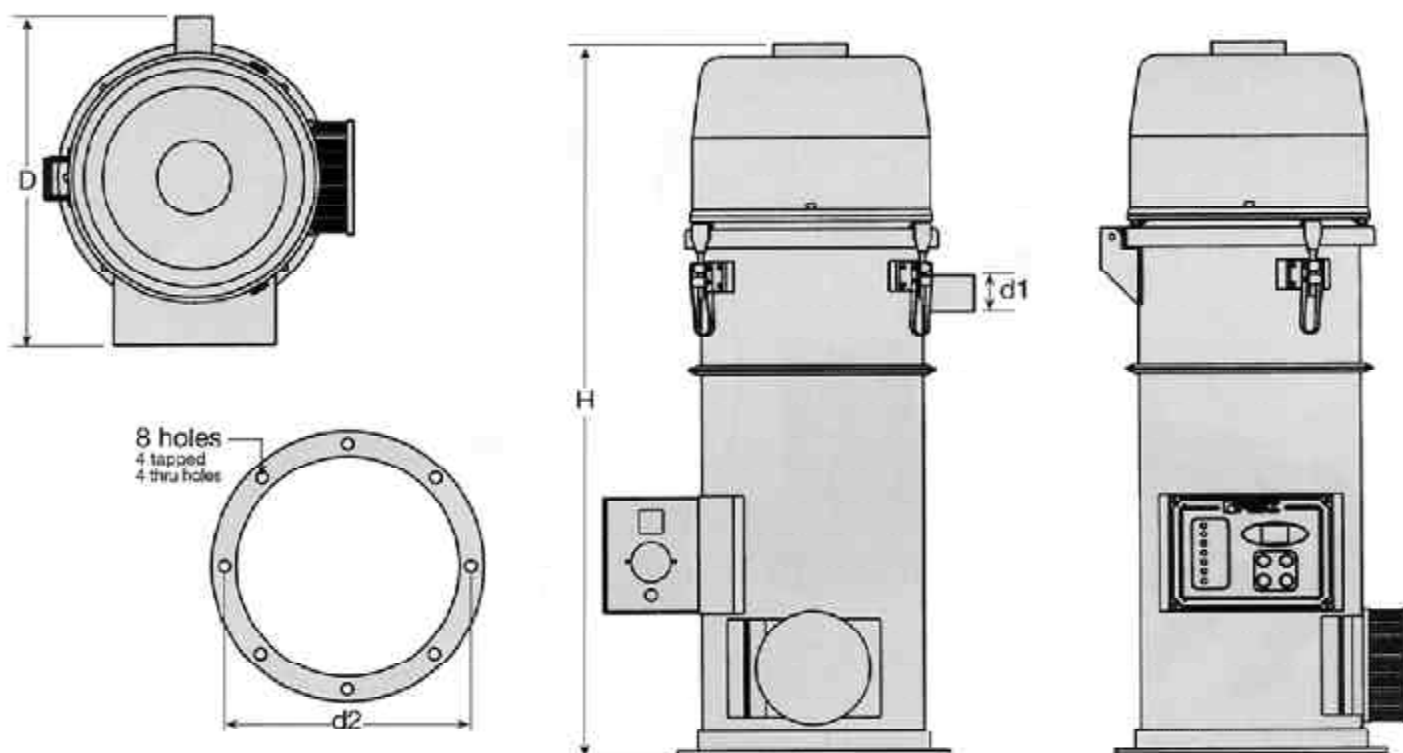

## E-Series Receivers Specifications

Model #		E3	E6	E12
<b>PRICE</b>		<b>\$740.00</b>	<b>\$790.00</b>	<b>\$870.00</b>
Hopper Capacity	cu in	183	366	732
Motor HP	HP	1.4	1.4	1.4
Throughput, max.	lb/hr	132	264	396
Loader Inlet Diameter (d1)	in	1.5	1.5	1.5
Bolt Hole Pattern (8 holes)(d2)	in	8.425	10.433	10.433
Depth (D)	in	13.15	13.66	13.66
Overall Height (H)	in	19.69	24.41	29.72
Weight, approx.	lbs	26	28	33



© 2004 MOLDERS CHOICE, Inc.

24 Hour Service - 7 Days a week

# 1-800-809-4623

 WebSite: [www.molderschoice.com](http://www.molderschoice.com) • Email: [molders@molderschoice.com](mailto:molders@molderschoice.com)