

Plastic LOCATING RING

Minimizes damage from incorrect mold setup.

If mold misalignment occurs, only the plastic ring gets damaged, instead of the platen, mold and heater bands.

Replaces industry-standard steel locating rings.

Cuts time from mold setups.

Made from reinforced, high-heat nylon.

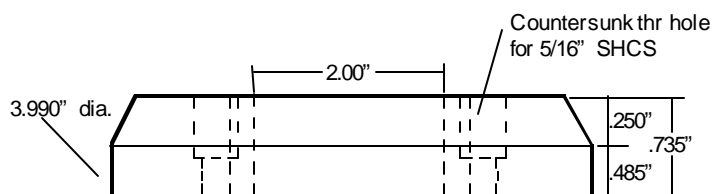

The LOCATOR™ is a trademark of G.A.I.M. Engineering.

Part No.	PRICE
PLR200	\$6.00

MOLD STRAP (G.A.I.M. T.O.I.)™

Protects Tool During Handling and Setup

Molded from Reinforced Nylon

During Handling ... strong enough to hold mold closed.

During Setup ... compounded to break apart before mold and machine are damaged if installer forgets to take off strap.

- Lower cost than standard strapping systems.
- Reusable

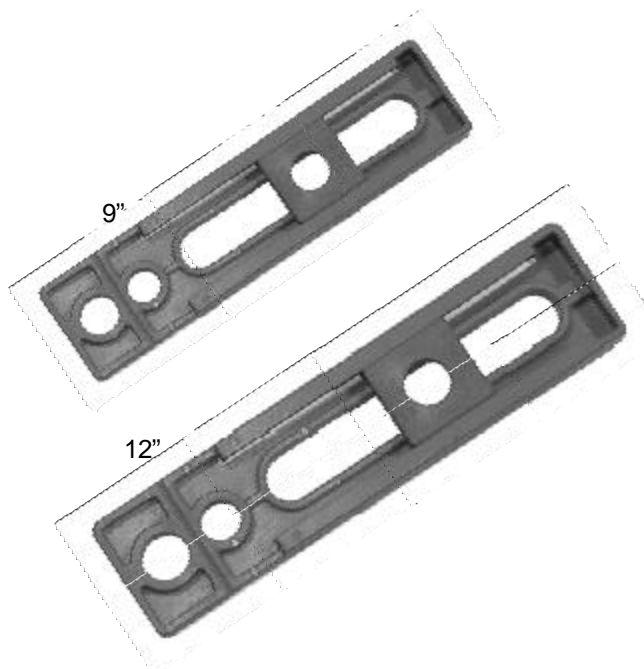

Part No.	Description	PRICE
TOI09	9" Mold Strap	\$6.00
TOI12	12" Mold Strap	\$6.50

G.A.I.M. T.O.I.™ is a trademark of G.A.I.M. Engineering.

© 2000 MOLDERS CHOICE, Inc.



24 Hour Service - 7 Days a week
1-800-809-4623
 WebSite: www.molderschoice.com • Email: modlers@molderschoice.com

Mold Identifying SMART CAPS

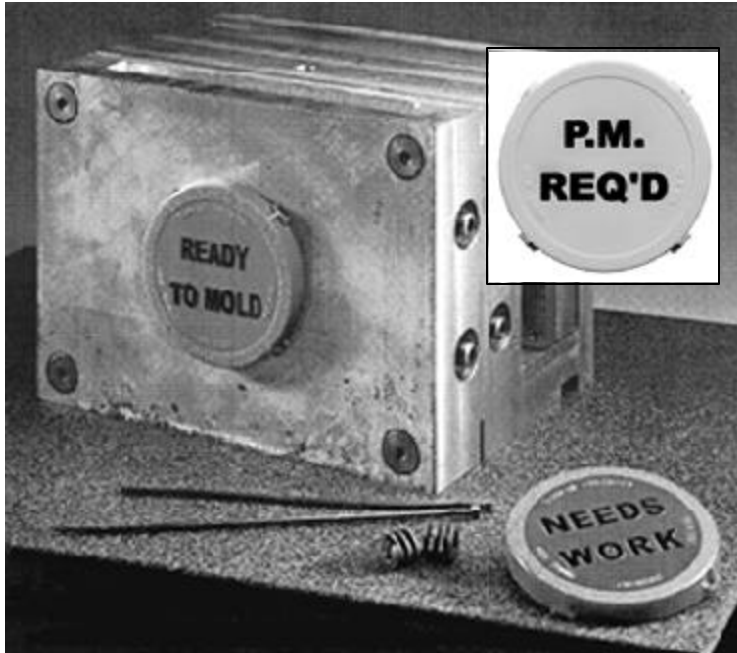

Snap onto Locating Ring to Indicate Status of Mold

- Prevents press setup with mold that is not ready.
- Prevents mold repair delays due to poor communication.

When repair, revision or engineering change is needed, molding room puts note or work order under **Red NEEDS WORK cap** and snaps it onto mold locating ring.

When standard preventive maintenance is needed, molding room puts note or work order under **Yellow P.M. REQ'D cap** and snaps it onto mold locating ring.

When work is done, tool room signs off on note or work order, puts it under **Green READY TO MOLD cap** and snaps it onto mold locating ring.

Part No.	Description	Price				
		1 to 9	10 to 19	20 to 49	50 to 99	100 +
GREENCAP	Green READY TO MOLD Smart Cap	\$2.25	\$2.12	\$2.07	\$1.98	\$1.85
REDCAP	Red NEEDS WORK Smart Cap	\$2.25	\$2.12	\$2.07	\$1.98	\$1.85
YELLOWCAP	Yellow P.M. REQ'D Smart Cap	\$2.25	\$2.12	\$2.07	\$1.98	\$1.85

Typical End-of-Run WorkFlow with Smart Caps

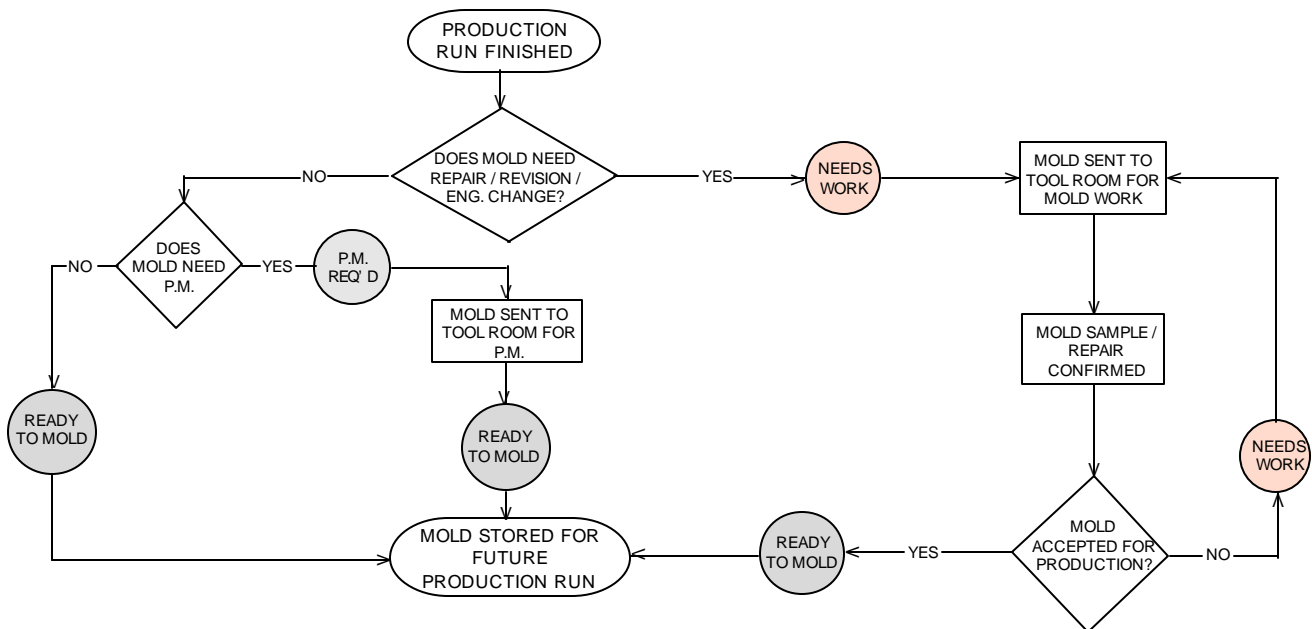

© 2000 MOLDERS CHOICE, Inc.



24 Hour Service - 7 Days a week
1-800-809-4623
 WebSite: www.molderschoice.com • Email: molders@molderschoice.com