

# FilterMix™ NOZZLES

## Filtration and Mixing in One Nozzle as Small as 7" Long

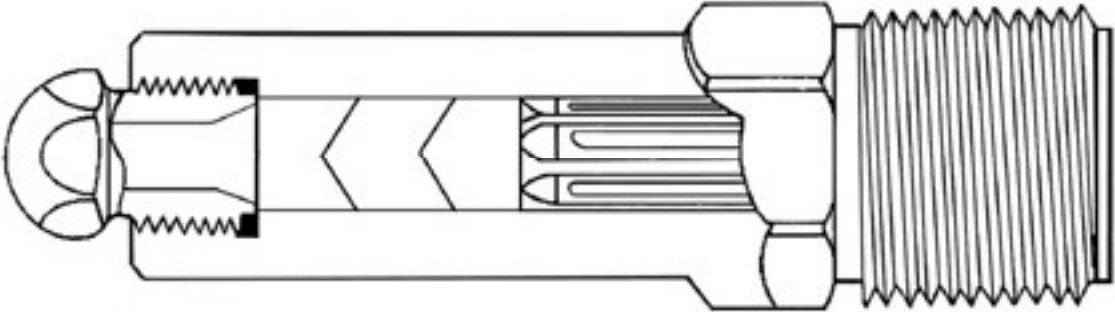

We developed the FilterMix™ for a midwest customer. It worked so well, we made it available to everyone.



- Combines the best of our proven Linear Edge Filter and Ultimate Mixing Nozzles.
- Maximum filtration and excellent mixing with minimum pressure drop.

Three mixer elements divide flow into multiple layers. Breaks up laminar flow. Evenly distributes color. Eliminates temperature gradients. Made from 304 stainless steel.



Filter traps metal down to .010" -- prevents hot-runner clogging. Made from 316 stainless steel.

**Minimum Length of Nozzle is 7" OAL**

- To Order Advise:
- A) OAL of Nozzle: \_\_\_\_\_
  - B) Thread size: \_\_\_\_\_
  - C) Rear opening: \_\_\_\_\_
  - D) Nozzle Tip Radius: \_\_\_\_\_ Orifice: \_\_\_\_\_
  - E) Heater Band Voltage: \_\_\_\_\_



© 2001 MOLDERS CHOICE, Inc.

**24 Hour Service - 7 Days a week**  
**1-800-809-4623**  
 WebSite: [www.molderschoice.com](http://www.molderschoice.com) • Email: [molders@molderschoice.com](mailto:molders@molderschoice.com)