

# CERAMIC HEATER BANDS

## for Injection Machine Barrels.

### Increase Recovery Rates

Higher watt-densities improve plastic melt

### Mold at Higher Temperatures

Ideal for molding exotic engineered materials, achieve temperatures to 1400° F or more.

### Very Efficient 3-Way Transfer

These " electric furnaces" develop heat transfer by conduction, convection and radiation.

### Lower Energy Costs

Built-in insulation minimizes heat loss, keeps heat transferring to barrel.

### Longer Life

Unlike conventional mica bands, a tight fit on the barrel is not necessary. No hot spots are developed when the fit is loose or irregularities exist on the barrel.

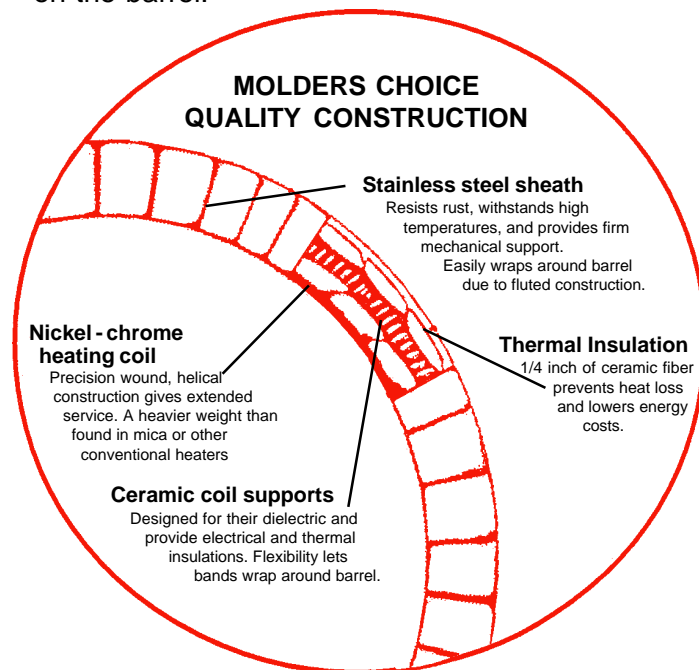

© 2009 MOLDERS CHOICE, Inc.



24 Hour Service - 7 Days a week  
**1-800-809-4623**  
WebSite: [www.molderschoice.com](http://www.molderschoice.com) • Email: [modlers@molderschoice.com](mailto:modlers@molderschoice.com)

# ADJUSTABLE CERAMIC HEATER BANDS



- LOWER ENERGY COSTS
- LONG LIFE

## The "MOLDERS CHOICE" in Heater Band Solutions

### SPECIFICATIONS:

TEMPERATURES: UP TO 1400° F  
 WATT DENSITY: UP TO 45 w/sq in.  
 INSULATION: 1/4" - thick ceramic fiber

LOCK-UP: Barrel and Nut

### VOLTAGE:

1-1/2" - wide bands : 2 post Terminals  
 240 Volt  
 2-1/2" -wide bands : 3 post Terminals  
 Can be wired for 240 or 480 Volt

**IN STOCK**

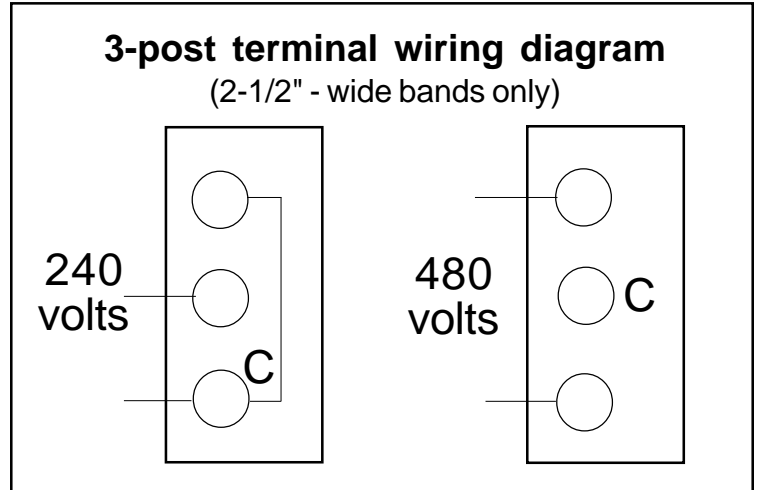

FITS BARREL DIAMETER		1-1/2" Wide			2-1/2" Wide		
STANDARD	METRIC	WATTS	PART #	PRICE	WATTS	PART #	PRICE
4 - 4-1/2	102-114	650	HBAC40-15	\$61.75	1100	HBAC40-25	\$70.00
4-1/2 - 5	114-127	750	HBAC45-15	\$64.30	1200	HBAC45-25	\$68.80
5 - 5-1/2	127-140	825	HBAC50-15	\$67.30	1300	HBAC50-25	\$72.10
5 -1/2 - 6	140-152	900	HBAC55-15	\$70.00	1500	HBAC55-25	\$75.00
6 - 6-1/2	152-165	1000	HBAC60-15	\$73.75	1650	HBAC60-25	\$77.85
6-1/2 - 7	165-178	1100	HBAC65-15	\$74.80	1750	HBAC65-25	\$80.80
7 - 7-1/2	178-190	1150	HBAC70-15	\$77.10	1900	HBAC70-25	\$83.60
7-1/2 - 8	190-203	1250	HBAC75-15	\$77.70	2000	HBAC75-25	\$86.50
8 - 8-1/2	203-216	1300	HBAC80-15	\$82.00	2200	HBAC80-25	\$89.30
8-1/2 - 9	216-229	1400	HBAC85-15	\$84.30	2300	HBAC85-25	\$92.15
9 - 9-1/2	229-241	1500	HBAC90-15	\$86.70	2475	HBAC90-25	\$110.00
9 -1/2 - 10	241-254	1575	HBAC95-15	\$90.15	2600	HBAC95-25	\$125.00
10 -10 - 1/2	254-268	1650	HBAC100-15	\$125.00	2750	HBAC100-25	\$145.00
10-1/2 - 11	68-280	1725	HBAC105-15	\$135.00	2875	HBAC105-25	\$155.00
11 - 11-1/2	280-292	1800	HBAC110 -15	\$155.00	3000	HBAC110-25	\$185.00

© 2009 MOLDERS CHOICE, Inc.



24 Hour Service - 7 Days a week  
**1-800-809-4623**  
 WebSite: [www.molderschoice.com](http://www.molderschoice.com) • E-mail: [molders@molderschoice.com](mailto:molders@molderschoice.com)