

NOZZLE BODIES

Most popular thread sizes in stock,
Quick delivery on Specials!

Simply Change The Tip!!

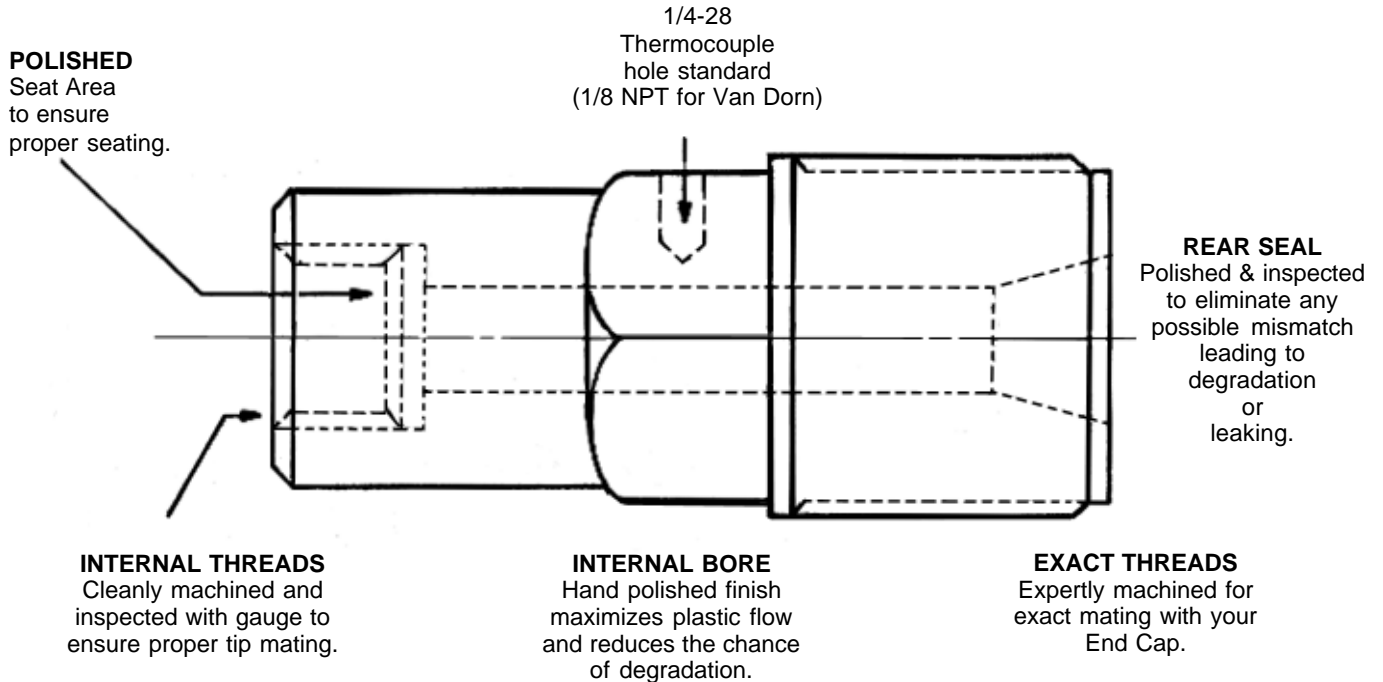

SPECIFICATIONS

- Alloy Steel 4140 or equivalent
- Heat Treated to 34-36 Rc for maximum toughness
- Super-smooth Internal finish - hand polished
- 100% Inspected
- Stocked in 5, 6, 7, 8, 9, 10, & 12" lengths
- For any make or model of machine
- All popular thread sizes in stock
- Can be customized to fit your application:
 - Special Thermocouple Holes
 - Pressure Transducer Holes
 - Melt Temperature Thermocouple Holes

See page 8 for special orders

© 2009 MOLDERS CHOICE, Inc.



24 Hour Service - 7 Days a week
1-800-809-4623
 WebSite: www.molderschoice.com • Email: molders@molderschoice.com