

SCREW REPAIR AND REPLACEMENT

Whenever you have a worn or damaged feedscrew, call MOLDERS CHOICE for advice on your best repair or replacement strategy.

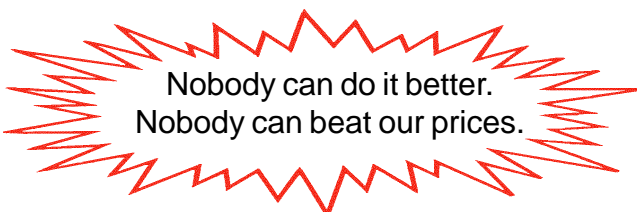

SCREW REPAIR

Depending on the screw size and the type and extent of damage, repair can save you 1/3 to 1/2 the cost of a new screw.

Each screw is Inspected to determine advisability of repairs, then quoted for your go-ahead before repairs are done.

Broken screws are joined and welded to original length. Damaged drive ends and tip ends are rebuilt.

Damaged threads are retapped (plugged and redrilled if needed); broken studs are extracted.

Worn or damaged flights and roots are undercut, then welded and reground to original specifications.

Screws are straightened (several times throughout process), then heat treated and surface treated (nitride or chrome).

Finally, every screw is inspected and coated in corrosion protective before shipment.

REPLACEMENT SCREWS

If It Can Be Built, We Can Build It.

Many Popular Sizes in Stock.
Specializing in Foreign Machines.

Any Material

- Nitralloy
- 4140
- CPM9V
- Hastelloy
- Stellite (flights)
- Colmonoy (flights)

Any Surface Treatment

- Heat Treated
- Nitrided
- Chrome Plated
- Flame Hardened

Any Design

Any Drive Type

Any Mixer Type

Custom Applications

CALL FOR PRICING AND LEAD TIMES



© 2009 MOLDERS CHOICE, Inc.

24 Hour Service - 7 Days a week
1-800-809-4623
WebSite: www.molderschoice.com • Email: molders@molderschoice.com

BARRELS

Stock Ion Nitrided & CPM10V Barrels

Many popular
sizes & machine
makes in stock!



Available in the following Materials:

- **135M** Nitralloy Nitrided – Basic offering
- **D-2** Tool Steel – Good Long Lasting Steel for General Purpose Material
- **CPM10V** Powdered Metal Tool Steel – A proven industry standard when processing glass filled material
- **CPM15V** Powdered Metal Tool Steel – The most wear resistant tool steel for glass & other abrasive materials
- **CPM420V** Powdered Metal Tool Steel – for corrosive applications
- **Bimetallics:** 3 Offerings
 - 1) Abrasion resistant
 - 2) Corrosion resistant
 - 3) Abrasion & corrosion resistant

Inquire about our Upsizing & Downsize
of Barrels & our quick turn-a-round on
Pre-owned / Re-worked Barrel Program



© 2009 MOLDERS CHOICE, Inc.

24 Hour Service - 7 Days a week

1-800-809-4623

WebSite: www.molderschoice.com • Email: molders@molderschoice.com

BARREL FRONT END CAPS

Smooth internal bore prevents material degradation
Precision machined for accurate seating of nozzle

Available in:

- 4140 Alloy Steel
- H13
- Nitralloy / Nitrided
- Chrome Plate

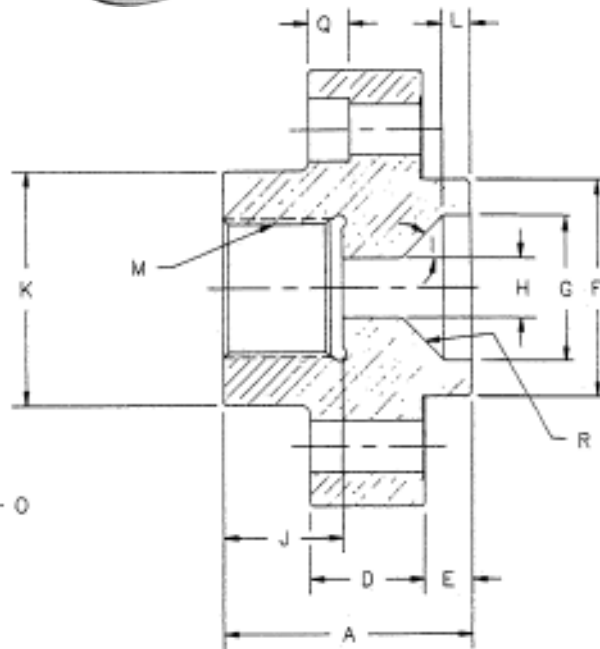
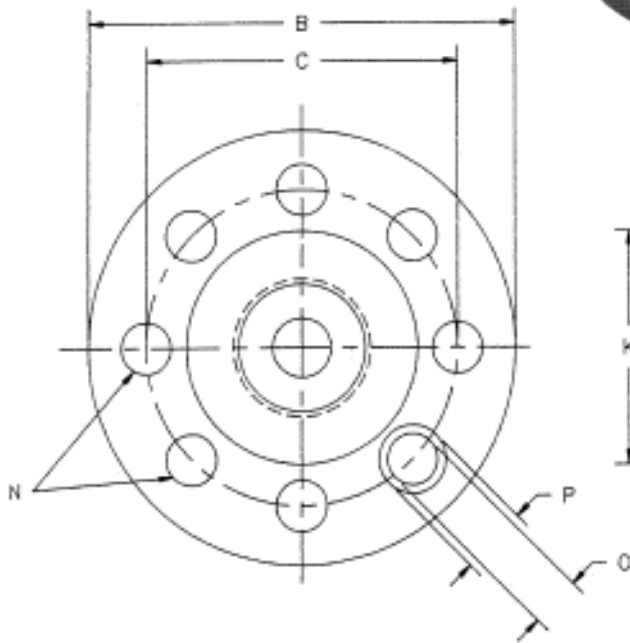

- A. Overall Length
- B. Flange Diameter
- C. Bolt Circle Diameter
- D. Flange Width
- E. Length of Pilot
- F. Pilot Diameter
- G. Rear Opening
- H. Bore Diameter
- I. Cone Angle

- J. Depth of Female Thread
- K. Nozzle Support Diameter
- L. Depth of Straight Bore
- M. Thread Type
- N. Number or Bolt Holes
- O. Bolt Hole Diameter
- P. Counter Bore Diameter (if any) ...
- Q. Counterbore Depth (if any)
- R. Surface Treatment

Indicate thermocouple hole position, depth and thread size

Any Make or Model End Cap can be made to your Sample or Drawing

©2009 MOLDERS CHOICE, Inc.



24 Hour Service - 7 Days a week
1-800-809-4623
 WebSite: www.molderschoice.com • Email: modlers@molderschoice.com

NEW BARREL or BARREL REPAIR

MOLDERS CHOICE is setting new standards of metalworking excellence for the plastics injection molding and extrusion industries. Since our inception, our focus has been to provide you with a cost-effective alternative to expensive, new, injection or extrusion barrels.

The majority of worn injection or extrusion barrels can be sleeved back to OEM specifications. In some cases, a relined barrel will actually be an upgrade from the original, at a fraction of the cost of a new barrel.

Wo Do Barrels Right

Our trained team of specialists has the knowledge and experience to reline and rework your barrels with a precision that meets or exceeds OEM specifications. Our goal is to be a world-class center of manufacturing excellence.

The Way You Want Them Done

We can make your worn injection or extrusion barrel better than the original one. Liners are available in standard or carbide bimetallic, D2 thru-hardened steel, D2 thru-hardened nitrided steel, or CPM-10V™ powdered metal.

How We Work

We make it simple and fast for you. Three simple steps.

- Ship your worn barrel to us.
- We'll do a complete inspection – top to bottom, front to back.
- We'll fax you a complete inspection report and our recommendations, price quote and delivery

What We Can Do

We are capable of relining your worn injection or extrusion barrels with a short sleeve, an XL liner or a full liner. We're able to reline barrels from 1-1/2"(38mm) to 6"(153mm) and with sleeve lengths up to 210"(5334mm)

SHORT SLEEVES

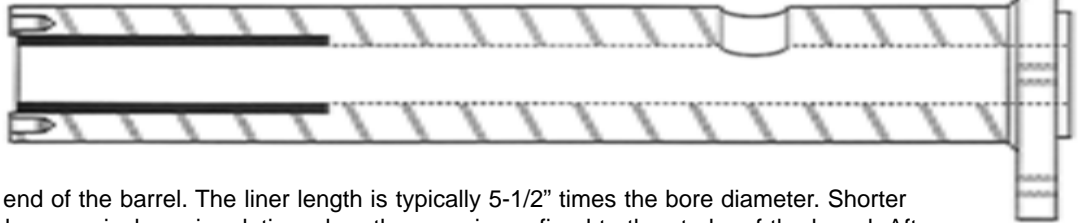

We can reline the shot end of the barrel. The liner length is typically 5-1/2" times the bore diameter. Shorter sleeves are a quick and economical repair solution when the wear is confined to the stroke of the barrel. After relining, the barrel is honed and the face and counterbore are remachined to ensure proper end cap alignment.

XL LINERS

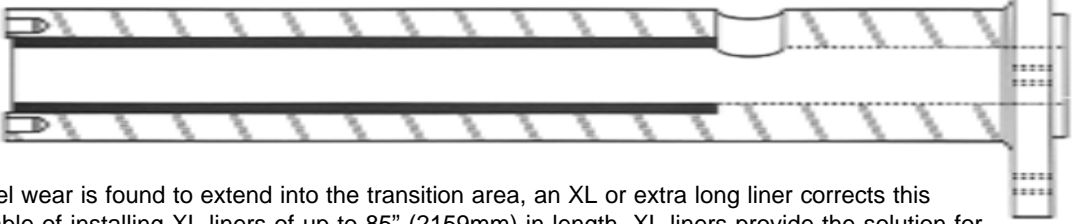

After inspection, if barrel wear is found to extend into the transition area, an XL or extra long liner corrects this condition. We are capable of installing XL liners of up to 85" (2159mm) in length. XL liners provide the solution for your extended wear problems.

FULL LENGTH LINERS

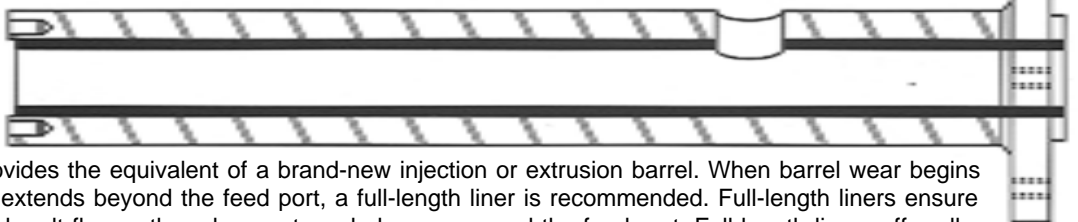

The full-length liner provides the equivalent of a brand-new injection or extrusion barrel. When barrel wear begins in the stroke area and extends beyond the feed port, a full-length liner is recommended. Full-length liners ensure a uniform, uninterrupted melt flow path and correct eroded areas around the feed port. Full length liners offer all the advantages of a new barrel.

© 2009 MOLDERS CHOICE, Inc.



24 Hour Service - 7 Days a week

1-800-809-4623

WebSite: www.molderschoice.com • Email: molders@molderschoice.com