

Linear Edge FILTER NOZZLE

A must for all Hot Runner Molds

- Traps Foreign Material
- Protects Hot-Runner Mold Gates.

- Maximum Protection
- Minimum Pressure Drop

Thousands Sold Worldwide

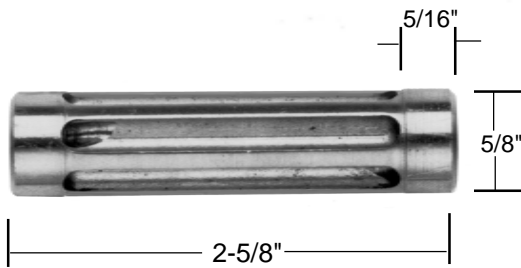
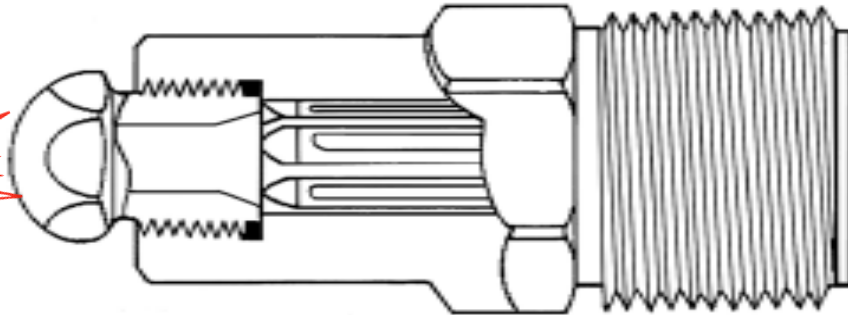

Material flows into rear-ported helical grooves, over barriers into adjacent front-ported grooves. .010" gap between groove barriers and nozzle I.D. traps foreign particles.

Also provides mixing action.

Standard Size fits any modified MOLDERS CHOICE removable-tip nozzle
Choose standard 316 Stainless Steel or long-wearing CPM9V Powder Metal Tool Steel.

Add Teeth for improved filtration and improved flow

CALL for Details

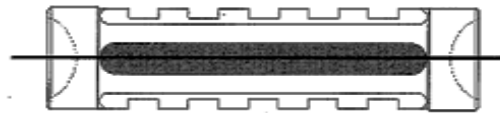

.020" to .050 teeth gap

Two ways to buy:

- A Filter only — modify your own nozzle (instructions included with filter).
- B Filter / Nozzle set — Purchased nozzle is machined to accept filter.

Part #	Description		Price
F1	Standard Size 316 Stainless Steel Filter	5/8" dia x 2-5/8 long	\$135.00
F1-9V	Standard Size CPM9V Filter	5/8" dia. x 2-5/8" long	\$245.00
F1-KONSS	Small, Kona-Compatible 316 Stainless Steel Filter	9/16" dia. x 1-3/4" long	\$200.00
F1-KON9V	Small, Kona-Compatible CPM9V Filter	9/16" dia. x 1-3/4" long	\$250.00
F2	Large 316 Stainless Steel Filter	.866 dia. x 4" long	\$185.00
F2-9V	Large CPM9V Filter	.866 dia. x 4" long	\$325.00

© 2009 MOLDERS CHOICE, Inc.



24 Hour Service - 7 Days a week
1-800-809-4623
 WebSite: www.molderschoice.com • Email: molders@molderschoice.com

Molders Choice "E" Universal Nozzle Tips

Patented TIP Controls or Eliminates Stringing, Drooling and Cold Slugs

- Reduce Downtime
- Decrease Rejected Parts
- Increase your margins
- Reduce Mold Damages
- Short Shot Control



One Advanced Universal Tip for All Your Jobs!

Eliminates the need of Stocking General Purpose, Nylon or Full Taper Tips

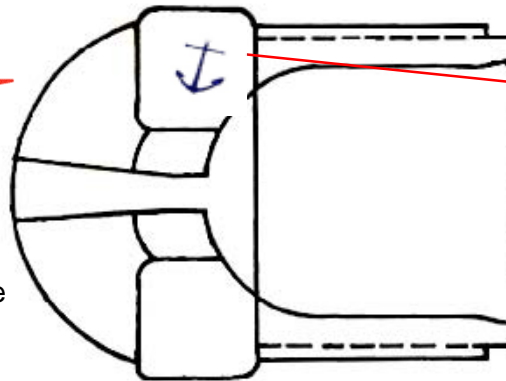
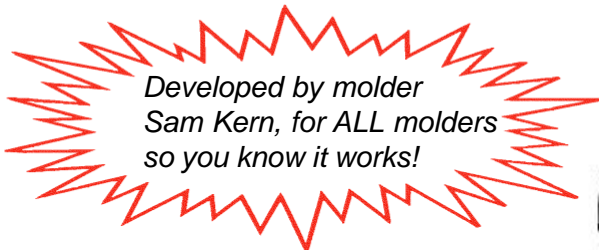

Look for the Anchor, to assure your getting the Original "E"

- Stocked in Standard 1-1/2"
- Other Orifice Sizes & Lengths available
- 1/2" and 3/4" Radius
- Industry standard 7/8-14 thread
- H13 Tool Steel Heated Treated R46-48

Patent #US006604933B1

- Couple the "E" Tip to our Coil Heated Nozzles and You have the Best Nozzle Temperature Control Money Can Buy!

Part #	Marking on Hex	Radius	Orifice	Overall Length	Material	PRICE
E5125	1	1/2"	1/8"	1-1/2"	Tool Steel	\$50.00
E5156	2	1/2"	5/32"	1-1/2"	Tool Steel	\$50.00
E5187	3	1/2"	3/16"	1-1/2"	Tool Steel	\$50.00
E5250	5	1/2"	1/4"	1-1/2"	Tool Steel	\$50.00
E5312	6	1/2"	5/16"	1-1/2"	Tool Steel	\$50.00
E7125	1	3/4"	1/8"	1-1/2"	Tool Steel	\$50.00
E7156	2	3/4"	5/32"	1-1/2"	Tool Steel	\$50.00
E7187	3	3/4"	3/16"	1-1/2"	Tool Steel	\$50.00
E7250	5	3/4"	1/4"	1-1/2"	Tool Steel	\$50.00
E7312	6	3/4"	5/16"	1-1/2"	Tool Steel	\$50.00

© 2011 MOLDERS CHOICE, Inc.



24 Hour Service - 7 Days a week
1-800-809-4623
 WebSite: www.molderschoice.com • Email: molders@molderschoice.com