

# Linear Edge FILTER NOZZLE

## A must for all Hot Runner Molds

- Traps Foreign Material
- Protects Hot-Runner Mold Gates.

- Maximum Protection
- Minimum Pressure Drop

Thousands Sold Worldwide

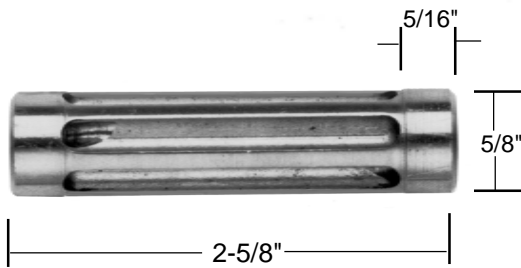
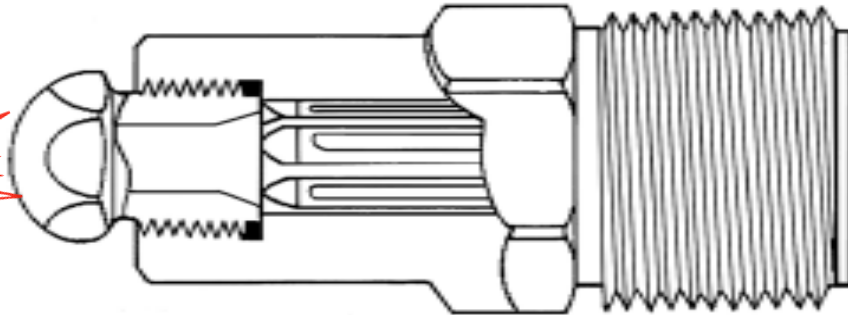

Material flows into rear-ported helical grooves, over barriers into adjacent front-ported grooves. .010" gap between groove barriers and nozzle I.D. traps foreign particles.

Also provides mixing action.

Standard Size fits any modified MOLDERS CHOICE removable-tip nozzle  
Choose standard 316 Stainless Steel or long-wearing CPM9V Powder Metal Tool Steel.

Add Teeth for improved filtration and improved flow

**CALL for Details**

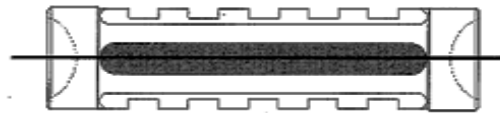

.020" to .050 teeth gap

**Two ways to buy:**

- A Filter only — modify your own nozzle (instructions included with filter).
- B Filter / Nozzle set — Purchased nozzle is machined to accept filter.

Part #	Description		Price
F1	Standard Size 316 Stainless Steel Filter	5/8" dia x 2-5/8 long	\$135.00
F1-9V	Standard Size CPM9V Filter	5/8" dia. x 2-5/8" long	\$245.00
F1-KONSS	Small, Kona-Compatible 316 Stainless Steel Filter	9/16" dia. x 1-3/4" long	\$200.00
F1-KON9V	Small, Kona-Compatible CPM9V Filter	9/16" dia. x 1-3/4" long	\$250.00
F2	Large 316 Stainless Steel Filter	.866 dia. x 4" long	\$185.00
F2-9V	Large CPM9V Filter	.866 dia. x 4" long	\$325.00

© 2009 MOLDERS CHOICE, Inc.



24 Hour Service - 7 Days a week  
**1-800-809-4623**  
 WebSite: [www.molderschoice.com](http://www.molderschoice.com) • Email: [molders@molderschoice.com](mailto:molders@molderschoice.com)