

CDH-Series Hot Air Dyers

The most effective way to dry plastic granules



The CDH-Series Advantage

The Comet CDH-Series dries plastic granules at the machine, avoiding the contamination or re-absorption of moisture found when conveying from a central drying position. You can continuously dry from 15 to 200 pounds per hour of plastic granules.

The CDH-Series Difference

In the CDH-Series, the hot air inlet is positioned at the top of the drying hopper. A stainless steel air tube runs through the center of the hopper to a diffuser at the bottom. The radiant heat from this tube helps to preheat the material.

In addition, cyclonic exhaust air dramatically improves the quality of the drying compared to other hot air models.

Standards Features:

- Fully stainless steel internal parts
- Hopper lid provides easy mounting of hopper loader
- Hopper cleanout door (CDH-50 and above)
- 7-day timer clock for auto startup (standard on CDH models 100-200)
- Adjustable overheat safety thermostat
- Main power isolator externally mounted as standard
- Electronics prepared for centralized drying installation
- Electrical circuit built to comply with CE safety requirements
- Clean-out door with inspection glass standard on CDH models 50-200

Options:

- 7-day timer clock for auto start-up on CDH models 15-75
- Temperature controller with full, digital display
- Hopper base assembly with or without magnet
- Shutoff slide valve
- Double-wall hopper
- Insulated hopper
- Drying up to 200°C (390°F)
- Mobile floor stand
- Dust filter



Can be mounted directly on machine or beside-the-press using optional stand

© 2009 MOLDERS CHOICE, Inc.



24 Hour Service - 7 Days a week
1-800-809-4623
 WebSite: www.molderschoice.com • Email: molders@molderschoice.com

CDH-Series Hot Air Dryers

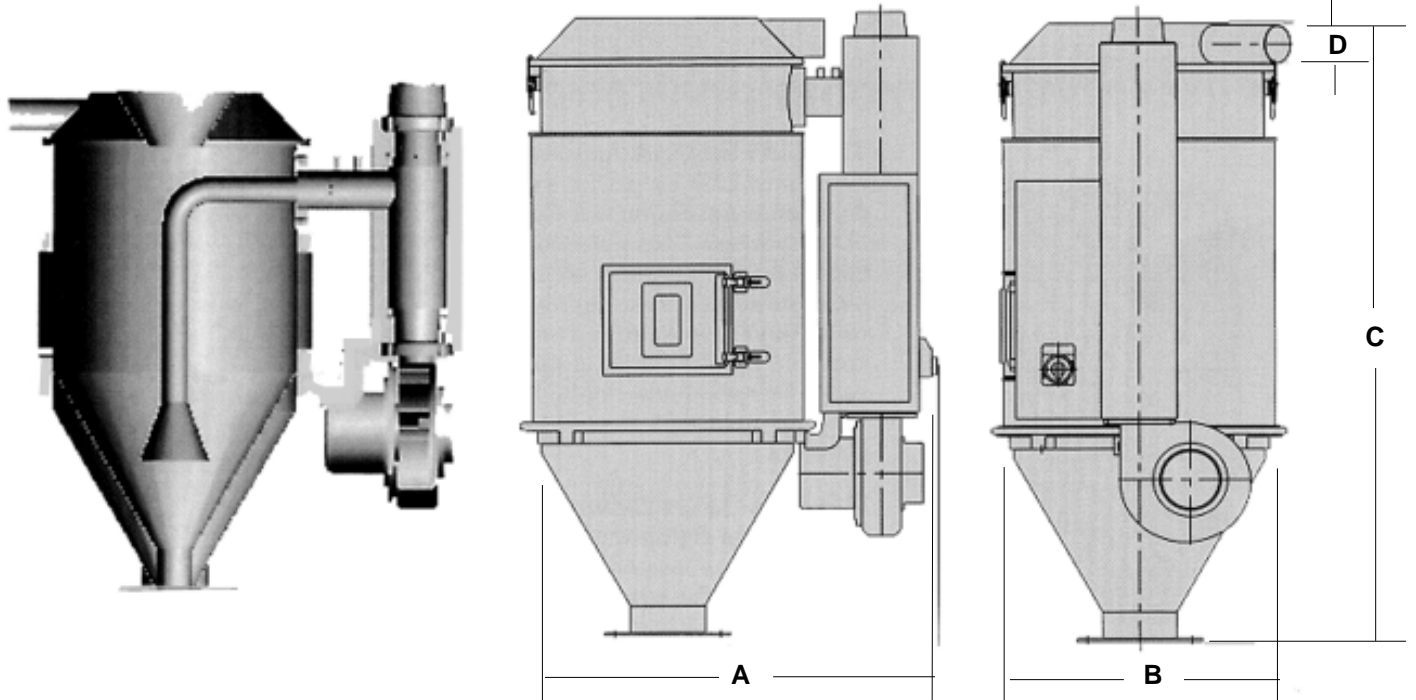

CDH-Series

Specifications – When Ordering Specify Voltage

Model #		15	30	50	75	100	150	200
PRICE		\$1650	\$1850	\$2085	\$2250	\$2525	\$3075	\$3400
Hopper Capacity	pounds	33	66	110	165	220	330	440
Hopper Capacity	cu ft	.9	1.8	3	4.4	6	8.8	11.8
Blower Motor	hp	1/18	1/11	1/8	1/8	1/8	1/4	1/4
Heating Capacity	kW	1.6	2.7	4.0	5.0	6.0	8.0	10.0
Drying Temp. Max		275° F or 150° C (390° F or 200° C as an option)						
7-Day Timer Clock		Option				Option		
Hopper Cleaning Door		N/A			Standard			
Width (A)	in	23.2	26.2	29.7	32.9	32.9	41.3	41.3
Depth (B)	in	16.5	17.9	20.1	23.2	23.2	29.1	29.1
Height (C)	in	25.0	32.3	37.0	40.2	48.8	59.1	71.7
Outlet Port (D)	in	1.5	2	2	2.5	2.5	3	3
Weight (approx.)	lb	66	99	132	176	220	308	330



© 2009 MOLDERS CHOICE, Inc.

24 Hour Service - 7 Days a week

1-800-809-4623

 WebSite: www.molderschoice.com • Email: molders@molderschoice.com