

300 lb RESIN HANDLING BIN

WAND OPENING
NOW LOCATED IN THE
TOP



DISCHARGE DOOR
FOR CLEANOUT / COLOR
CHANGE PURPOSES

New, Redesigned
Model with the wand
opening now
at the top to allow up
less pour around
the press

Molded
with FDA
Approved Resin,
Also includes
Anti Static Adder

Capacity:
300 lb (136 kgs) or 8.57 cu. ft.

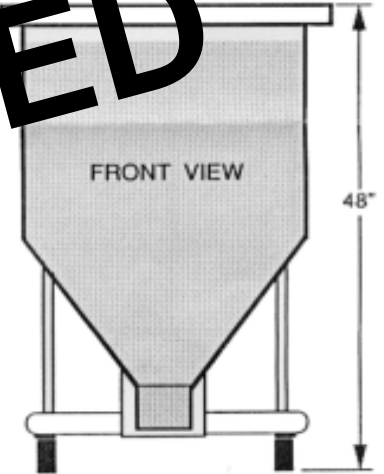

TOP VIEW

Self-Emptying Resin Handling Bins are designed for use with vacuum loading systems using pickup wands. An angled chute directs the material to the wand at the lowest point in the bin, where gravity feeds the resin to the wand for pickup. A cleanout door facilitates fast and thorough bin cleaning for material / color changes. All bins includes the lid and heavy duty casters.

PART #	PRICE

© 2009 MOLDERS CHOICE, Inc.



24 Hour Service - 7 Days a week
1-800-809-4623
 WebSite: www.molderschoice.com • Email: molders@molderschoice.com