

STANDARD LONG RADIUS BENDS - 90°

11 & 16 GAUGE MATERIAL

1-1/4" OD
1-1/2" OD
1-3/4" OD
2" OD
2-1/8" OD
2-1/2" OD
3" OD
3-1/2" OD
4" OD

For larger ODs,
please call.

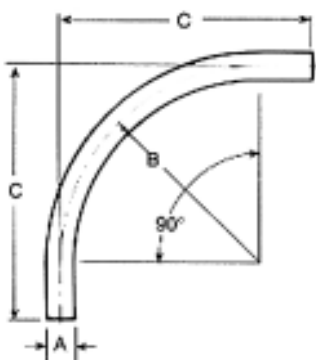

All standard bends have straight ends. Expanded ends are available upon request, except on 8" and 10" bends.

Nominal Standard Tangent is Two Times Tube OD, 6" minimum.

OD = Outside Diameter
CLR = Center Line Radius

All reference dimensions are nominal.

NOTE: First two digits of part number below indicate gauge

PART NO.	A O.D.	B CLR	C	WEIGHT S STEEL	STAINLESS	ALUMINUM	WEIGHT ALUM.
16-200182	2"	18"	24"	4.7	INQUIRE		1.6
11-200182	2"	18"	24"	8.4			2.2
16-200242	2"	24"	30"	5.8			2.0
11-200242	2"	24"	30"	10.5			3.6
16-200362	2"	36"	42"	8.1			2.8
11-200362	2"	36"	42"	14.6			5.0
16-212242	2-1/8"	24"	30"	5.3	ON		2.0
11-212242	2-1/8"	24"	30"	10.6			3.5
16-212362	2-1/8"	36"	42"	8.6			2.8
11-212362	2-1/8"	36"	42"	13.0	4.9		
16-250242	2-1/2"	24"	30"	7.0	ALL		2.4
11-250242	2-1/2"	24"	30"	12.6			4.5
16-250362	2-1/2"	36"	42"	9.2			3.3
11-250362	2-1/2"	36"	42"	16.9			5.7
16-300242	3"	24"	30"	8.5	PRICING		2.8
11-300242	3"	24"	30"	14.4			5.1
16-300302	3"	30"	36"	10.4	DUE TO		3.5
11-300302	3"	30"	36"	18.2			6.3
16-300362	3"	36"	42"	11.6			4.0
11-300362	3"	36"	42"	21.1			7.3
16-300482	3"	48"	54"	15.3			5.1
11-300482	3"	48"	54"	26.9			8.8
16-350302	3-1/2"	30"	37"	11.9	OF		4.1
11-350302	3-1/2"	30"	37"	21.7			8.0
16-350362	3-1/2"	36"	43"	14.0			4.9
11-350362	3-1/2"	36"	43"	25.5			9.0
16-350482	3-1/2"	48"	55"	17.5			6.2
11-350482	3-1/2"	48"	55"	32.3			12.0
16-400242	4"	24"	32"	12.6	STEEL		4.5
11-400242	4"	24"	32"	22.3			8.5
16-400302	4"	30"	38"	13.5	PRICING		5.0
11-400302	4"	30"	38"	26.2			9.0
16-400362	4"	36"	44"	16.5			5.9
11-400362	4"	36"	44"	33.2			10.4
16-400482	4"	48"	56"	20.5			7.2
11-400482	4"	48"	56"	37.7			13.5

Other items available. . .
Call Molders Choice

Coating available for highly abrasive materials

© 2009 MOLDERS CHOICE, Inc.



24 Hour Service - 7 Days a week

1-800-809-4623

WebSite: www.molderschoice.com • Email: molders@molderschoice.com

STANDARD LONG RADIUS BENDS - 45°

NOTE: First two digits of part number below indicate gauge

11 & 16 GAUGE MATERIAL

- 1-1/4" OD
- 1-1/2" OD
- 1-3/4" OD
- 2" OD
- 2-1/8" OD
- 2-1/2" OD
- 3" OD
- 3-1/2" OD
- 4" OD

For larger ODs, please call.

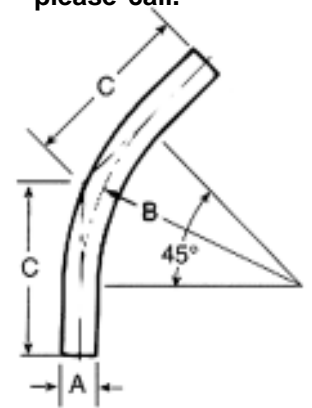

All standard bends have straight ends. Expanded ends are available upon request, except on 8" and 10" bends.

Nominal Standard Tangent is Two Times Tube OD, 6" minimum.

OD = Outside Diameter
CLR = Center Line Radius

All reference dimensions are nominal.

Other items available. . .
Call Molders Choice

PART NO.	A OD	B CLR	C	WEIGHT S STEEL	STAINLESS ALUMINUM	WEIGHT ALUM	
16-200181	2"	18"	13-7/16"	3.1	INQUIRE	1.6	
11-200181	2"	18"	13-7/16"	5.5		2.9	
16-200241	2"	24"	15-15/16"	3.7		2.0	
11-200241	2"	24"	15-15/16"	6.6		3.6	
16-200361	2"	36"	20-15/16"	4.8		2.8	
11-200361	2"	36"	20-15/16"	8.7		5.0	
16-212241	2-1/8"	24"	15-15/16"	3.8	ON	3.1	
11-212241	2-1/8"	24"	15-15/16"	6.6		2.0	
16-212361	2-1/8"	36"	20-15/16"	4.8		1.6	
11-212361	2-1/8"	36"	20-15/16"	7.8	2.8		
16-250241	2-1/2"	24"	15-15/16"	4.3	ALL	1.5	
11-250241	2-1/2"	24"	15-15/16"	7.8		2.8	
16-250361	2-1/2"	36"	20-15/16"	5.0		1.7	
11-250361	2-1/2"	36"	20-15/16"	9.7		3.3	
16-300241	3"	24"	15-15/16"	5.0	PRICING	1.7	
11-300241	3"	24"	15-15/16"	9.0		3.0	
16-300301	3"	30"	18-7/16"	5.5	DUE TO FLUCTUATION	1.8	
11-300301	3"	30"	18-7/16"	10.9		3.6	
16-300361	3"	36"	20-15/16"	6.8		2.4	
11-300361	3"	36"	20-15/16"	12.4		4.3	
16-300481	3"	48"	25-7/8"	8.5		2.9	
11-300481	3"	48"	25-7/8"	15.8		5.0	
16-350301	3-1/2"	30"	19-7/16"	7.4		OF	2.5
11-350301	3-1/2"	30"	19-7/16"	14.4			4.9
16-350361	3-1/2"	36"	21-15/16"	8.4	2.9		
11-350361	3-1/2"	36"	21-15/16"	15.3	5.4		
16-350481	3-1/2"	48"	26-7/8"	10.2	3.6		
11-350481	3-1/2"	48"	26-7/8"	18.6	6.9		
16-400241	4"	24"	17-15/16"	8.5	STEEL	3.0	
11-400241	4"	24"	17-15/16"	15.7		5.8	
16-400301	4"	30"	20-7/16"	9.1	PRICING	3.1	
11-400301	4"	30"	20-7/16"	16.4		6.0	
16-400361	4"	36"	22-15/16"	10.0		3.8	
11-400361	4"	36"	22-15/16"	21.2		7.2	
16-400481	4"	48"	27-7/8"	12.2		4.2	
11-400481	4"	48"	27-7/8"	22.2		7.6	

Coating available for highly abrasive materials



© 2009 MOLDERS CHOICE, Inc.

24 Hour Service - 7 Days a week
1-800-809-4623
 WebSite: www.molderschoice.com • Email: molders@molderschoice.com